

NARES Capacity in Relation to International Treaties and Conventions on Intellectual Property Rights, Agricultural Biotechnology, and Plant Genetic Resources Management

Leocadio Sebastian

PhilRice, Philippines

Email: leo_sebastian@yahoo.com

Jane G. Payumo

PhilRice, Philippines

Email: jpayumo4@wsu.edu

ABSTRACT

Significant developments in the scientific front and international policy arena have affected the use and exchange of genetic resources, and the management of intellectual property. These developments are now reshaping public agricultural research and development (R&D) in developing countries, especially in the access, generation, and dissemination of research outputs. Three of the most important international treaties and conventions that are important in this context are the World Trade Organization's Agreement on Trade-Related Aspects of Intellectual Property Rights (WTO-TRIPS), the Convention on Biological Diversity (CBD), and the International Treaty on Plant Genetic Resources for Food and Agriculture (ITPGRFA). Already, majority of the developing countries are signatories to these treaties and could be expected to exploit them for their own advantage. On the other hand, non-member countries, despite their non-participation, must find alternative scenarios to be able to effectively address issues concerning IPR, agricultural biotechnology, and plant genetic resources.

As the main source of innovation in public agricultural research, national agricultural research extension systems (NARES) need to be enlightened on the various aspects of these treaties and agreements and the impact on their respective research and extension activities. It may be necessary, for example, to tailor capacity-building initiatives on the IPR, agbiotech, and PGR aspects of international treaties to specific countries or regions since policy and enforcement mechanisms among NARES vary according to the availability of human and logistical resources, research priorities, and technology transfer objectives.

This paper takes a look at the critical aspects of TRIPS, CBD, ITPGRFA, and other agreements, and studies their implications on public agbiotech R&D among NARS; compares initiatives by several Asian developing countries to comply with the provisions of these treaties and agreements; highlights PhilRice's initiatives to help its national government comply with its obligations under these treaties; and assesses and recommends a plan of action on the capacity-building of NARES institutions on IPR, agbiotech, and PGR management.

INTRODUCTION

As the main source of innovation in agricultural research, the national agriculture research and extension systems (NARES) are facing ever-increasing demands to improve their performance and respond more adequately to developmental issues in their internal and external environments. Rapid advances in science and technology are occurring in various areas as a result of research and development (R&D) efforts by public and private sector institutions, as well as international research organizations. International legal regimes are also expected to effect changes in terms of technology acquisition and exploitation strategies, R&D focus, and dissemination of agricultural R&D outputs.

An emerging catalyst of the next major increases in agricultural productivity and profitability is agricultural biotechnology or agbiotech, for short (Marra 2002; Prakash 2003; James 2008). Although most of its benefits to date have been conferred in the developed world, substantial evidence increasingly confirms that biotechnology has the potential to contribute to agricultural production. Its principal application to agriculture at present is to produce improved crops, and in the next two decades, this is likely to be its major use, thereby possibly contributing in a big way to the eradication of hunger and poverty (Borlaug 2002).

However, ethical concerns about the deployment and use of agbiotech do not sit well with intellectual property (IP). The application of intellectual property rights (IPRs) to plant varieties and the role of agbiotech, for example, are deemed important, given the impact of access to biological and genetic resources on the world's agriculture systems, food security, and poverty levels (Diaz 2005).

The World Trade Organization's Agreement on Trade-Related Aspects of Intellectual Property Rights (WTO-TRIPS), the Convention on Biological Diversity (CBD), and the International Treaty on Plant Genetic Resources for Food and Agriculture (ITPGRFA) are some of the most discussed legal international treaties. The changing "rules of the game" offered by the international legal regimes present both opportunities and challenges to developing countries, and the public agricultural sector, in particular.

This paper discusses the implications of these international treaties and conventions relative to

IPR, agbiotech, and plant genetic resources (PGR) among the NARES of developing countries in Asia. It presents a review of the international regulatory framework; the status of compliance of developing countries in Asia and their initiatives in IPR, agbiotech, and PGR management; the positive and negative implications of international regime development to public agbiotech R&D; a case study on PhilRice and its initiatives to address IPR and biosafety issues concerning its agbiotech R&D activities; and an assessment and recommended plan of action for other NARES in Asia to effectively address IPR, agbiotech, and PGR management issues.

REVIEW OF THE INTERNATIONAL REGULATORY FRAMEWORKS

International treaties and agreements do regulate the use and commercialization of agbiotech products, but in the process, exact a myriad of obligations from member-countries. Since international treaties are also construed as statutes and reconciled with local laws, member-countries have to enact complementary and/or supplementary legislation (Beronio et al. 2006), thus creating significant impact on their national policies. The UNCTAD-ICTSD (2003) likewise notes that some of the coverage of these international treaties and agreements overlap to a significant degree, and sometimes provide conflicting objectives for developing countries to adopt.

Setting International IP Standards through WTO-TRIPS¹

The establishment of the WTO has extended trade rules into every field of economic endeavor, and has expanded the purview of trade agreements from the original trading of goods across international borders to investment measures, domestic regulatory initiatives, and services, and more importantly, IPRs. IPRs are rights over intellectual property conferred by national law, making it territorial, and form part of a nation's policy to encourage innovation and dissemination of knowledge, and

¹ See more discussion on TRIPS at TRIPS Gateway, WTO website at www.wto.org/english/tratop_e/trips_e/trips_e.htm

are therefore intended to balance the interests of the inventor or originator with the broader needs of society.

TRIPS covers the IPR rules and provisions for WTO members and represents the state of IP standards today. Under this international agreement, member-countries are obliged to provide most of the existing types of IPR protection, namely: (1) copyright and related rights, (2) trademarks, (3) geographical indications (GI), (4) industrial designs, (5) patents, including plant variety protection, (6) layout designs (topographies) of integrated circuits, (7) protection of undisclosed information (or trade secrets), and (8) control of anti-competitive practices in contractual licenses. TRIPS incorporates and holds valid all previous international provisions of some administered treaties and conventions by the World Intellectual Property Organization (WIPO). It also specifies detailed requirements for the substantive content of national IPR legislation such as the extent of coverage, terms of protection, and mechanisms of enforcement. It also brings national IPR legislation under the coverage of WTO dispute settlement procedures. National treatment, most-favored-nation, and minimum standards are the important main principles enshrined in this agreement. As of 16 May 2008, 152 members had ratified this treaty.

Repetto and Cavalcanti (2000) state that Articles 22-24 and 27-34 on GIs and patents, respectively, are the provisions that affect agbiotech and agriculture since they regulate the protection of agriculture-related IPR, above all, protected plant varieties and patented inventions, including genetically modified organisms (GMOs). GI aims to safeguard a specific description or presentation, in relation to products used, to indicate the geographical origin of the goods; by geographical origin is meant a country, region, locality, or linear feature to which a product may be attributed as being customarily harvested or manufactured there. As an element in the *sui generis* system, this protection is proposed to protect farming community-based varieties, traditional knowledge, and plant varieties or animal breeds that already have or may gain favorable international or national reputation, or some distinctive foods and products like Basmati and Jasmine rice. The life-patenting

provisions of Article 27, on the other hand, are the most controversial of the TRIPS provisions. Specifically, Article 27.3(b) allows members to exclude from patentability plants and animals other than microorganisms, and essentially biological processes for the production of plants or animals other than non-biological and microbiological processes. It, however, requires members to provide for the protection of plant varieties either by patents or by an effective *sui generis* system or by any combination thereof. The plant breeders' rights (PBRs) provided in the UPOV convention is one special system member-countries can adopt to protect its varieties. India has a special PVP law that incorporates plant breeders' rights and farmers' rights.

Since January 1, 1995, a total of 37 disputes have been recorded concerning TRIPS (WTO 2008) encompassing patent issues, TRIPS per se, TRIPS enforcement, trademarks, and GI.

Ensuring Food Safety and Animal and Plant Health through WTO's SPS

One issue regarding the commercialization of genetically modified products is food safety, that is, that they comply with animal and plant health standards when they are internationally traded. The Sanitary and Phytosanitary (SPS)² measures set out the basic rules for WTO members. It, however, provides leeway for countries to set their own standards and requires that measures: 1) do not discriminate between member-states; 2) conform where possible to international standards developed by the 1963 Codex Alimentarius Commission, or the 1997 International Plant Protection Convention (IPPC); 3) be based on scientific principles and the completion of a risk assessment study; and 4) do not constitute a disguised restriction on international trade. According to WTO's Committee on SPS Measures, as of May 2005, 139 WTO Members had identified a national notification authority; 130 had established an SPS enquiry point, and 87 had notified at least one new or revised SPS measure.

² More specific discussion on this WTO agreement is available at http://www.wto.org/english/tratop_e/sps_e/spsagr_e.htm

WIPO's Administered IP Treaties

The oversight of international IP issues is conducted largely by WIPO. It administers 24 treaties³, which establish substantive IP standards, and has 183 participating member-states. WIPO has a Working Group on Biotechnology, which identifies interlinking issues on agbiotech and IPR. It also has an Intergovernmental Committee (IGC) on Intellectual Property and Genetic Resources, Traditional Knowledge and Folklore that drafts provisions for the protection of traditional cultural expressions/folklore (TCEs) and for the protection of traditional knowledge against misappropriation and misuse. Several experts, however, are critical of the current initiative of WIPO called the 'WIPO Patent Agenda'⁴, which according to Musungu and Dutfield (2002), are likely to result in TRIPS-plus standards. The Substantive Patent Law Treaty (SPLT) is specifically considered the most difficult piece of the puzzle for WIPO today⁵. The SPLT's current negotiation picks up from where the PLT ended. It aims to harmonize as much as possible the substantive contents of patent laws, the rules on what can and cannot be patented, and what is sufficient proof of patentability.

UPOV's Plant Breeder's Rights (PBRs)

The PBR system evolved by the International Union for the Protection of New Varieties of Plants (UPOV) Convention is a kind of *sui generis*⁶ system of protection specifically tailored to the art of plant breeding, and the nature of modern cultivars. A new plant variety must be distinct, uniform, and stable in order to be granted PBRs.

PBRs maintain the fundamental principle of unrestricted access to genetic resources (FAO 1991) through its provisions for "Breeders' Exemption" and "Farmers' Privilege"⁷. The UPOV Convention, first adopted in Paris in 1961, came into force in 1968 and has been revised in 1972, 1978, and 1991⁸. As of April 3, 2006, UPOV has 61 member-countries.

WIPO notes the benefits of the UPOV System for small and medium enterprises (SMEs) as 1) lowering "barriers to entry" into the breeding sector, 2) its simple and harmonized application translates to lower costs and simplified filing procedures in foreign countries, and 3) the harmonization of variety examination focused on distinctness, uniformity, and stability (DUS). The Genetic Resources Action International (GRAIN 1998), the Commission on Intellectual Property Rights (CIPR 2002), and other non-government organizations (NGOs), however, argue that PBRs as a form of protection will impinge upon the breeding activities in and for developing countries. Further, the provisions of the new UPOV Convention will interfere with FAO's proposed balance between PBRs and "Farmers' Rights"⁹.

United Nations' Convention on Biological Diversity (CBD)

Known informally as the Biodiversity Convention, this treaty which entered into force in 1992 aims to sustain the diversity of life on Earth and recognizes that the conservation of biological diversity is "a common concern of humankind". Consisting of 42 articles, the legally-binding CBD states its objectives as: "*the conservation*

³ See detailed information on WIPO treaties and membership at WIPO website, www.wipo.int/treaties/en/

⁴ The risks to developing countries of the WIPO Patent Agenda are discussed in-depth by Correa and Masungu (2002). Available at www.southcentre.org/publications/wipopatent/toc.htm

⁵ See Grain (2003) for their views on WIPO's proposed SPLT at <http://www.grain.org>

⁶ Literally meaning 'of its own kind', this refers to the system of protection for new plant varieties where member-countries can make their own rules to protect new plant varieties with some form of IPR, provided that such protection is effective.

⁷ The Breeder's Exemption allows plant breeders to use freely protected plant varieties as a source of genetic variability for further breeding, without having to seek permission, or pay royalties. The Farmers' Privilege is the right to re-use seed they have harvested for the next year's sowing, without either having to ask permission, or pay royalties to the holder of the Plant Breeders' Rights over the crop variety in question.

⁸ See comparison of UPOV acts in Helfer (2004), "Intellectual Property Rights in Plant Varieties: International Legal Regimes and Policy Options For National Governments". FAO, Pp. 14-21. [Note: Is the portion enclosed in parentheses the title of the article? Pls also include the title of the bigger work from which this article is taken. Is FAO the publisher? Alternatively, the footnote may refer only to "Helfer 2004" but a complete entry on this work must be made in the List of References.

⁹ This was approved by FAO in 1989 and defined as "rights arising from the past, present and future contributions of farmers in conserving, improving and making available plant genetic resources, particularly those in the centres of origin/diversity".

of biological diversity; the sustainable use of its components; and the fair and equitable sharing of the benefits arising out of the utilization of GR, including the appropriate access to GR and by appropriate transfer of relevant technologies". CBD likewise affirms that States have sovereign rights over their genetic resources and have the authority to determine access to genetic resources subject to national legislation, and that any use of these resources should be (i) based on prior informed consent and (ii) for the mutual benefit of both parties [Article 15]. Such prior informed consent for the use of genetic material implies extra requirements on the criteria for granting patents. Other important CBD provisions are Articles 8, 9, 10, 16, and 19 which include provisions dealing with *in situ* and *ex situ* conservation, and access to GR, among other things. There are 188 country governments party to CBD, 168 of whom have ratified it (CBD 2008).

CBD's Cartagena Protocol on Biosafety

The Biosafety Protocol, which is part of the CBD package was adopted in January 2000 and entered into force in September 2003; it provides an international regulatory framework to ensure the safe transfer, handling, and use of living modified organisms (such as seeds, trees, or fish), *that may have adverse effects on the conservation and sustainable use of biological diversity, taking also into account risks to human health, and specifically focusing on transboundary movements*¹⁰. To date, 147 instruments of ratification or accession have been deposited with the UN Secretary-General.

The precautionary approach is the Protocol's guiding principle and its central directive is that the import of living modified organisms (LMOs) into a signatory country for release requires the advance informed agreement of the country's focal point and competent national authorities¹¹. In the Philippines, for instance, the national focal point is the Department of Foreign Affairs; the National Committee on Biosafety is the Biosafety

Clearing House focal point; and the Departments of Agriculture, Environment and Natural Resources, Science and Technology, and Health are the competent national authorities (DENR 2004).

International Treaty on Plant Genetic Resources for Food and Agriculture (ITPGRFA) of the Food and Agriculture Organization (FAO)¹²

This came into force on June 29, 2004, and presently has 105 members. Its adoption was a culmination of the series of negotiations on the International Undertaking on Plant Genetic Resources (IUPGR), administered by FAO's Commission on Genetic Resources for Food and Agriculture. The IUPGR specifically was born out of demands from developing countries that the exchange of plant genetic resources (PGR) be regulated to correct the growing asymmetry between the availability of the so-called "improved" varieties produced from formal breeding and the availability of farmers' landraces and other traditional varieties (Bragdon 2000).

Prior to this agreement, PGRFA were relatively freely exchanged among farmers in their communities, and from continents to continents, promoting intra-specific diversity. This has happened not only among farmers in their communities but also from continent to continent. These resources, though, are unequally distributed thus creating inter-dependency among countries for their conservation and sustainable use (Pistorius 1995). The ITPGRFA offers distinctive solutions to ensure that these particular PGRs vital for food security be kept accessible to all farmers, and in the public domain. Its centerpiece is a 'multilateral system' for access and benefit-sharing, which for certain categories of PGRFA guarantees facilitated access in return for fair benefit-sharing.

Composed of 35 article provisions, this legally binding treaty is in harmony with CBD. The CBD and ITPGRFA complement each other in dealing with access to PGRs (Asia Pacific Consumer 2003). The ITPGRFA, like CBD, provides a certain

¹⁰ An introduction to the Cartagena Protocol on Biosafety prepared by the Secretariat of the Convention on Biological Diversity and the United Nations Environment Programme is accessible at www.biodiv.org/biosafety/

¹¹ National focal points are responsible for managing communication between the Secretariat and respective governments, and the public, while the competent national authority is responsible for performing the administrative functions required by this Protocol and which shall be authorized to act on its behalf with respect to those functions.

¹² See more of ITPGRFA at www.fao.org/ag/cgrfa/itpgr.htm

measure of flexibility to ensure that community and farmers' rights are protected (FAO 2004). It, however, reduces bureaucratic procedures inherent in bilateral negotiations of the kind stipulated in the CBD (Choudhary 2002). The ITPGRFA promotes multilateral access and adoption of standard terms and conditions such as those provided in the standard MTA, which is in accordance with the CBD¹³. The MTA can greatly reduce, or avoid altogether, the necessity to conclude individual bilateral agreements on germplasm access and the distribution of possible benefits, and could substantially reduce bureaucracy and transaction costs overall. During the first ITPGRFA Governing Body meeting held in Rome in June 2006, the use of the sMTA as the single document to govern PGR access and benefit-sharing was approved, with the FAO chosen as the third party to act in behalf of all signatories regarding benefit-sharing arrangements.

Other key outstanding issues associated with this seed treaty include those dealing with the conservation, exploration, collection, characterization, evaluation and documentation of PGR for food and agriculture; the sustainable use of PGR; farmers' rights; and *ex situ* collections of PGR for food and agriculture held by the centers of the Consultative Group on International Agricultural Research (CGIAR) and other international institutions.

Issues and Concerns of Developing Asian Countries

Asia, with a land area of 4.38 billion ha, is home to more than four billion people or about 60% of the world's population (Wikipedia 2008). The United Nations Educational, Scientific, and Cultural Organization (UNESCO 2006) Institute of Statistics reported that the region provided 35.6% share to the world's gross domestic product (GDP) in 2002. The region is also the second leader in scientific investment, with public and private funding accounting for 32% of the world's gross expenditure on research and development (GERD) in 2002.

Developing countries in Asia actively participate in international treaties and agreements but not all are members of all the agreements discussed (Table 1). All of the countries are members of TRIPS, with 11 on observer status. Four countries namely Bhutan, Brunei, Kazakhstan, and Singapore are not CBD members. Azerbaijan and Kazakhstan are not WIPO members. Likewise, not all WIPO members are signatory to all the treaties administered by WIPO. India, for instance, is not a signatory to the Madrid Protocol while Thailand is only a WIPO member and did not ratify any WIPO treaty. Only 37% (13) of these countries have ratified ITPGRFA while only a few (22%) are UPOV members.

As indicated in the FAODec database, most of these countries have national policies on biotechnology research, biosafety, patents, PVP, and PGR. Table 2 presents a comparison of specific country initiatives with respect to regulating agbiotech, IPR, and PGR. India has the most number of laws on IPR while Indonesia has the most number of laws on biosafety and PGR. Vietnam has the least legislation on biosafety for transgenic products while Thailand has the least national policy on PGR management.

State of Asia's Agbiotech R&D Implementation and Management

Biotechnology research in developing countries in Asia focuses on food crops and crops of high commercial value (Hautea and Escaler 2004). The interest of Asian developing countries in agbiotech depends on such factors as: 1) whether they are net food importers or exporters; 2) how extensive their biodiversity is; 3) the nature of their farming economy; 4) the degree of industrialization; and 5) whether they have an established biotech industry. Biotech research is currently being carried out in both public and private organizations, which may have either national or multinational mandates.

Biotechnology Application

According to FAO (2005), in relation to the traits introduced in the transgenic crop varieties,

¹³ See the First session report of the Governing Body of the International Treaty on Plant Genetic Resources for Food and Agriculture held on June 12, 2006 for the complete article provisions of the MTA available at www.fao.org/ag/cgrfa/gb1.htm

Table 1. Membership of Asian countries in international treaties and conventions.

| Country* | Membership in Selected International Treaties/Conventions | | | | | | | |
|-----------------|---|-------|-----|------|----------|---------|---------|---------|
| | Members | TRIPS | CBD | WIPO | WIPO-PCT | WIPO-PC | WIPO-MP | ITPGRFA |
| Azerbaijan | x** | x | - | X | x | - | - | x |
| Armenia | x | x*** | x | X | x | x | - | - |
| Bahrain | x | x | x | X | x | x | - | - |
| Bhutan | x** | - | x | - | x | x | - | - |
| Brunei | x | - | x | - | - | - | - | - |
| China | x | x*** | x | x | x | x | - | x |
| Georgia | x | x | x | x | x | x | - | - |
| India | x | x*** | x | x | x | - | x | - |
| Indonesia | x | x*** | x | x | x | - | x | - |
| Iran | x** | x | x | x | x | x | x | - |
| Iraq | x** | x | x | - | x | - | - | - |
| Israel | x | x | x | x | x | - | - | x |
| Jordan | x | x*** | x | - | x | - | x | x |
| Korea | x | x | x | x | x | x | - | x |
| Kazakhstan | x** | - | - | x | x | - | - | - |
| Kuwait | x | x | x | - | - | - | x | - |
| Kyrgyz Republic | x | x*** | x | x | x | x | - | x |
| Lao PDR | x** | x | x | x | x | - | - | - |
| Lebanon | x** | x | x | - | x | - | x | - |
| Malaysia | x | x*** | x | x | x | - | x | - |
| Mongolia | x | x*** | x | x | x | x | - | - |
| Oman | x | x*** | x | x | x | - | x | - |
| Pakistan | x | x | x | - | x | - | x | - |
| Philippines | x | x | x | x | x | - | x | - |
| Qatar | x | x | x | - | x | - | - | - |
| Saudi Arabia | x | x | x | - | x | - | x | - |
| Sri Lanka | x | x*** | x | x | x | - | - | - |
| Singapore | x | - | x | x | x | x | - | x |
| Thailand | x | x*** | x | - | - | - | x | - |
| Tajikistan | x** | x | x | x | x | - | - | - |
| Turkey | x | x*** | x | x | x | x | x | - |
| UAE | x | x | x | x | x | - | x | - |
| Uzbekistan | x** | x | x | - | x | - | - | x |
| Vietnam | x** | x | x | x | x | x | - | - |
| Yemen | x** | x | x | - | - | - | - | - |

Sources: CBD (2006); FAO (2006); WIPO (2006); PCT (Patent Cooperation Treaty); PC (Paris Convention); MP (Madrid Protocol).

*List is based on Asian countries included in FAO database.

** WTO observers that are in negotiations for full membership or about to start accession.

the research focus of developing countries in Asia is resistance to pathogens and pests, herbicide tolerance, abiotic stress tolerance, or modifications to quality traits. A number of non-GM (genetic modification) biotechnologies are also currently being used, and these include plant propagation, microbial applications, molecular markers, and diagnostics. The dominant Asian countries doing agbiotech R&D are Japan, China, India, and Singapore. Thailand, Korea, and the Philippines

have likewise started building their capabilities in agbiotech R&D. According to the International Service for the Acquisition of Agri-Biotech Applications (ISAAA 2006), China, India, the Philippines, and Iran are among the 21 countries worldwide growing genetically modified crops covering about 11.60 million acres¹⁴.

¹⁴ See complete report on the Global Status of Commercialized Biotech/GM Crops: 2005 at www.isaaa.org/

Table 2. Initiatives by some Asian developing countries in regulating agbiotech, IPR, and PGR.

| Country | Patent/PVP | Biosafety | PGR |
|-----------|---|---|--|
| China | Patent Law Regulation Concerning Protection of Wild Plants 1997 Regulation of the People's Republic of China on the Protection of New Varieties of Plants, 1999 | 'Safety Administration Regulation on Genetic Engineering' (MOST), 1993 'Safety Administration Implementation Regulation on Agricultural Biological Genetic Engineering' (MOA), 1996 'Regulation on the Safety Administration of Agricultural GMOs' (State Council), 2001 | Regulation Concerning the Management and Protection of Wild Herbal Resources, 1987 Law of Seeds, 2000 Regulations on Protection of Traditional Industrial Arts and regulations on Protection of Varieties of Traditional Chinese Medicine. |
| India | Law on The Protection of Plant Varieties and Farmers' Rights (PPV and FR) Act, 2001 Patents Act No 39, 1970 Patents Amendment Act, 1994 Patents rules, 2005 Patents ordinance, 2004 | Environmental Protection Law, 1986 Recombinant DNA Guidelines, (Ministry of Science, Dept. of Biotechnology), 1990 | Patent (Second Amendment) Act, 2002 Draft Biological Diversity Bill, 2000 Draft Kerala Tribal Intellectual Property Rights Bill, 1996 Draft Karnataka Community Intellectual Rights Bill, 1994 |
| Indonesia | Enactment of Law Number 29 of Plant Variety Protection, 2000; Law Number 14 on Patent, 2001 | Act no. 16 Quarantine for Animals, Fish and Plants (1992) Food Act No. 7 (1996) Minister of Health Decree No. 382 (1989) on Compulsory Registration for Food. Minister of Agriculture No. 86 on the Provisions of Biosafety of Genetically Engineered Agricultural Biotechnology Products (1997) Government Regulation No. 69 concerning Label and Advertisement for Food (1999) | Act No. 29 Plant Variety Protection (2000) Act on Spatial Use Management, 1992 Plant Cultivation Act, 1992 Draft Genetic Resources Management Act Act No.5 Conservation of Natural Resources and its Ecosystem (1990) Act No. 12 System for Plant Culture (1992) Act No. 23 Environmental Management Act (1997) |
| Malaysia | Patents Act No 291, 1983 Patents Amendment Act, 2000 Protection of New Plant Variety Act, 2004 | Guidelines for the release of GMOs | Biodiversity Policy Draft Access and Benefit- Sharing Law |

Table 2. (Continued).

| Country | Patent/PVP | Biosafety | PGR |
|-------------|--|--|--|
| Pakistan | Patents and Designs Act, 1911 Patents Ordinance, 2000, 2002 Plant Breeders Rights Ordinance, 2000 | Environment Protection Act, 1997 | Draft Access to Biological Resources and Community Rights Bill |
| Philippines | Republic Act 8293 (IP Code of the Philippines), 1998 Republic Act 9168 (PVP Act), 2002 | Executive Order 430 National Committee on Biosafety of the Philippines Department of Agriculture Administrative Order No. 8, 2002 | Wildlife Resources Conservation and Protection Act, 2001 Indigenous Peoples Rights Act, 1997 Executive Order No. 247 on bioprospecting, 1995 Draft Community Intellectual Rights Protection Act, 1994 |
| Thailand | Amendment of the 1989 Thai Patent Act B.E. 2522, 1999 Enactment of the Plant Variety Protection Act B.E. 2542, 1999 | Plant Quarantine Act B.E. 2507 (1964) Act of Import and Export Products to Kingdom Act B.E. 2522 The Food Act B.E. 2522, 1979 | The National Environment Conservation and Promotion Act B.E. 2535, 1992 Thai Traditional Medicine Act, 1999 Draft Community Forest Act, 1996 |
| Vietnam | Patent Decree No 63/CP, 1996 Decree No 13 on Plant Variety Protection | Biosafety Regulations for GMOs and products, 2005 | Agreement between the US and Vietnam on Trade Relations, 2000 Law on Environmental Protection, 1993 Land Law, 1993 |

Sources: Country reports from the Genetic Resources and Intellectual Property Rights Training held in Svalof, Sweden, May-June 2005; GRAIN and Kalpavriksh (2002); and FAO Biodec Database (2005).

Table 3. Status of research and application of crop biotechnologies in Asia (as of 2005).

| Technique | C | T | E | U | N |
|----------------------------------|----|----|----|----|----|
| Microbial techniques | - | - | 20 | 6 | 7 |
| Tissue culture | 18 | 9 | 92 | 64 | 10 |
| Molecular markers | - | - | 33 | 28 | 9 |
| Diagnostic techniques | - | - | 7 | 4 | 7 |
| GMO with pathogen resistance | 2 | 19 | 35 | 14 | 9 |
| GMO with pest resistance | 3 | 16 | 17 | 14 | 7 |
| GMO with herbicide resistance | - | 5 | - | 6 | 4 |
| GMO with abiotic stresses | - | 5 | 7 | 6 | 6 |
| GMO with improved quality traits | 2 | 3 | 27 | 4 | 8 |
| GMO with multiple resistance | - | 3 | 2 | - | 3 |

C: technology used on a routine basis and products available in the market; T: results being tested; E: number of activities at experimental level (including laboratory of glasshouse activities); U: activities in unknown phase; N: number of countries involved.

Source: FAO (2005).

The FAO (2005) also reports that tissue culture dominates crop biotechnologies in Asia in terms of the amount of commercialized activities, those in the laboratory stage, and the number of countries using them (Table 3). Many of the plant cell-and tissue-culture technologies have been readily available for many years, and have been taken up where appropriate, such as in the micro-propagation of vegetatively propagated crops like banana and date palm. Genetic engineering is focused more on pathogen resistance, followed by pest resistance. Asia is also reported to have fewer activities in producing genetically modified organisms with multiple resistances.

Biosafety Regimes and Constraints

The Cartagena Protocol and related obligations have been understood or interpreted in various ways in the region, as reported by the International Union for Conservation of Nature and Natural Resources (IUCN 2003). To address this, ASEAN countries have adopted the ASEAN Guidelines on Risk Assessment and Management of Agriculture-Related GMOs in an attempt to enhance the harmonization of national laws and regulations pertaining to biosafety. Countries that have final drafts of NBF include Cambodia, Indonesia, Laos, Myanmar, Philippines, and Vietnam. Brunei, Malaysia, Singapore, and Thailand have no NBFs yet, as reported by the United Nations Environment Program (<http://www.unep.org/biosafety/>). The Regional Biodiversity Programme (RBP) aims to

help these countries through its project “Capacity Building to Implement the Biosafety Protocol in Asia” that aims to: help countries in Asia to implement national and international regulations concerning biosafety; build the capacity to integrate provisions of international and national-level regulations; and support personal and institutional-level activities aimed at implementing the Cartagena Protocol. Another initiative, namely, the Program for Biosafety Systems (PBS) of the United States Department of Agriculture is likewise assisting developing countries to enhance their biosafety policy, research, and capacity.

Asia’s IPR Policies and Enforcement

The levels of IPR management and enforcement of Asian countries differ depending on the sophistication of their economies, links with western countries with strong IPR regimes, and their stage of industrial development. Deng et al. (1996) reported that majority of Asian countries have enacted their first IPR laws recently, essentially patterned after TRIPS, and many of those with IPR laws have weak enforcement mechanisms. IP enforcement remains elusive and problems with IPR protection vary according to category. Overall, however, developing countries in Asia are presently initiating actions and making good progress in establishing adequate IPR acquisition, maintenance, and enforcement to fulfill their obligations under international treaties (Beronio and Payumo 2006). Many countries are currently incorporating IP issues into their

economic, industrial, and technological planning, and into research and education programs.

International and Regional IP Membership

Most of the Asian developing countries are WTO members and observers, with 33 having acceded and ratified the GATT-WTO since 1995. Ten more countries are on observer status and expected to join. In particular, according to Tanasugarn (2002), most Southeast Asian nations have patent laws in compliance with TRIPs particularly in areas like the exclusion of patentable subject matter, patentable man-made microorganisms, compulsory licensing, and sui generis laws for protecting new plant varieties. Evenson et al. (2002) observes that all of the Asian sui generis laws for plant variety protection are based on UPOV and therefore have much in common especially in terms of provisions on farmers' privilege. GRAIN (1999), however, observes that countries such as India, Bangladesh, and Pakistan take substantial distance from UPOV. Countries such as India, Bangladesh, the Philippines, and Thailand include "progressive"¹⁵ and biosafety provisions for farmers and indigenous communities in their otherwise predictable PVP acts. Additionally, the Philippine draft requires that varieties be subject to an Environmental Impact Assessment, which is a common legal tool in the country and covers both socioeconomic concerns and parameters on genetic diversity.

Most countries are also signatories to the WIPO, Paris Convention, and Patent Cooperation Treaty. The Asia-Pacific Economic Cooperation (APEC) and the ASEAN are designing regional cooperation programs to strengthen commitments to IPR treaties. ASEAN, for instance, through the IPR Action Plan for 2004-2010, aims to consider issues and implications in accession and compliance with international IP treaties focused on the WIPO Internet Treaty, Madrid Protocol (Trademark), Hague Agreement concerning the International

Deposit of Industrial Designs, Paris Convention for the Protection of Industrial Property, Berne Convention for the Protection of Literary and Artistic Works, Patent Cooperation Treaty, and Budapest Treaty on the International Recognition of the Deposit of Microorganism for the Purposes of Patent Procedure. This plan also aims to improve IP legislation, protection and enforcement; and review and align domestic IP laws and regulations for TRIPS conformance among WTO members of ASEAN.

Enforcement Problems

ASEAN in its IPR Action for 2004-2010 admits that IPR protection and enforcement is probably among the weakest links in the chain despite strong IPR regimes [in principle]. Several Asian countries are still included in the United States Trade Representatives' (USTR) Special 301 list, which categorizes many countries as IPR infringers and promoters of unfair trade practices. The USTR notes the widespread IPR violations on patents in Korea; trademarks in Thailand and the Philippines; and copyrights in China, Thailand, Indonesia, and Korea. China's weak IPR protection and enforcement continue to be the priority for monitoring by USTR. India, Indonesia, Kuwait, Pakistan, the Philippines, and Turkey are still in the priority watch list, while ten others are in the watch list. These violations involve mostly entertainment softwares, optical disc (music and films) piracy, and manufacturing and distributing counterfeit goods and pharmaceuticals. The issue of IPR enforcement is important to encourage more foreign direct and private sector investment flows, and technology transfer.

The Domestic Response to PGR Management

Asia is home to several mega-centers of biodiversity but large areas face severe genetic erosion (Bioiversity International 2008). Another relevant issue in the region is biopiracy (Panutampon and Lianchamroon 1998). A close variant of this scenario was played for the Jasmine rice of Thailand, and Basmati rice of India. In both cases, variants of the two rice varieties have been patented and copyrighted by United States firms. This expanded scope of IPRs and their extension to

¹⁵ The progressive provisions refer to, among others, the inclusion of farmers in the definition of breeders, making derogations [note: pls check with author the use of the preceding word because of its negative connotations] for farmers and tribal groups to apply for PVP, and setting up special funding mechanisms for in situ conservation of genetic resources.

biological materials effectively enable institutions of researchers to appropriate the resources and knowledge of farmers and indigenous communities. IP claims relating to plants and human genetic material have provoked charges of biopiracy in many regions.

Biological Diversity, Access, and Benefit Sharing

Developing countries in Asia have been keen to promote their own plant breeding efforts, and to protect their diversity and the rights and interests of local communities responsible for promoting and maintaining diversity, as reflected in Article 8 of the CBD. Creation, modification, and implementation of national laws concerning PGR are evident in several governments, with many also aiming to legally protect biodiversity and related traditional knowledge.

Active Groups

The Bioversity International, formerly the International Plant Genetic Resources Institute (IPGRI), is one of the active CGIAR centers implementing programs to promote better conservation and use of the region's PGR. Its Asian counterparts include 1) the Regional Network for Conservation and Utilization of Plant Genetic Resources in East Asia (EA-PGR); 2) the Regional Co-operation in Southeast Asia for Plant Genetic Resources (RECSEA-PGR); and 3) the South Asia Network on Plant Genetic Resources (SANPGR) (Bioversity International).

Set up in 1991, EA-PGR provides the mechanism for sharing and exchanging information, discussing and identifying common interests, and initiating and developing collaborative activities among China, Japan, Republic of Korea, Democratic People's Republic of Korea, and Mongolia. Established in 1993, RECSEA-PGR is the most developed network and has Indonesia, Malaysia, the Philippines, Papua New Guinea, Thailand, Singapore and Vietnam as current members. SANPGR, formerly called the South Asia Coordinators Network, was established in 1990 and has six members: Bangladesh, Bhutan, India, Maldives, Nepal and Sri Lanka. The objectives of these three networks center on:

promoting documentation systems in national PGR programs; sharing PGR and information among member-countries; strengthening national programs on PGR by providing advice and training opportunities; coordination of research activities to avoid duplication of efforts; implementation of a cooperative program with common interests; and the improvement of the conservation and use of PGR in the respective regions.

IMPLICATIONS OF INTERNATIONAL AGREEMENTS ON AGBIOTECH R&D FOR ASIAN NARES

Since majority of the Asian countries are signatories to the TRIPS, CBD, and ITPGRFA, these treaties have to be reconciled with their local legislation and complemented and/or supplemented by national laws and policies (Beronio et al. 2006). Each country therefore has to promulgate several laws parallel to these treaties and these require new investments, decisions, and challenges that would impact on the agricultural research system and the nation in general.

Figure 1 charts and summarizes how these international treaties and national laws will impact on public R&D institutions. The TRIPS, CBD, and ITPGRFA will indirectly affect the following:

- 1) the development of R&D programs and priorities on biotechnology and PGR management;
- 2) the monitoring, selection, access, adoption, and modification of new tools and technologies from the public agricultural sector like the IARC (International Agricultural Research Centers), the CGIAR (Consultative Group on International Agricultural Research) system, academic institutions, and the private sector;
- 3) the development of technology transfer mechanisms to commercialize, promote, and diffuse these agbiotech innovations from laboratories to farmers at the domestic level guided by IPR policies, biosafety issues, breeders' rights, farmers' rights, and PGR policies;
- 4) the promotion and enhancement of relationships with IARCs and other public sector R&D laboratories; and

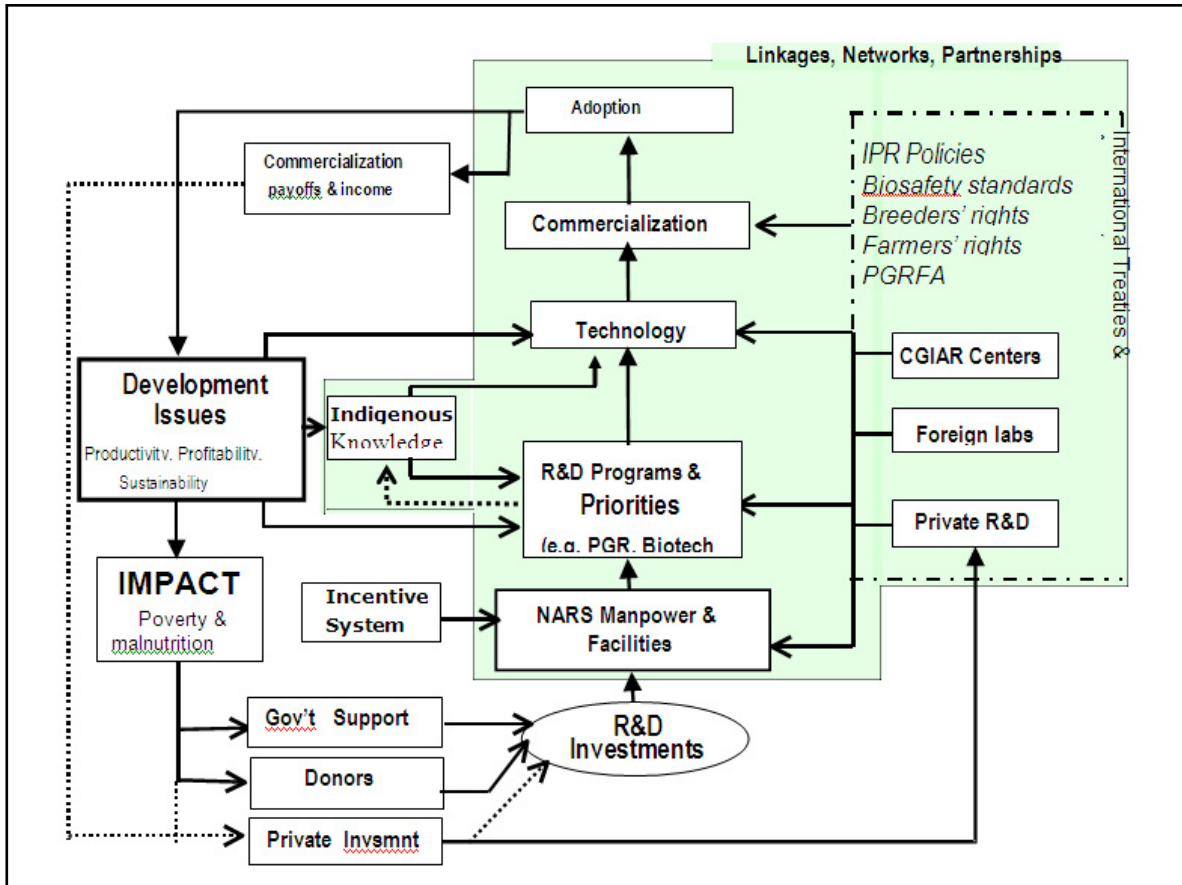

Fig. 1. Developing country's innovation system.

- 5) the promotion of better partnerships with the private sector as an important source of technologies and funding support.

Further, the indirect compliance with international policy mechanisms entails a strong internal environment among public sector R&D institutions to deliver technological innovations, such as those produced by agbiotech. These critical components would be: 1) trained and competent human resources, with effective indigenous knowledge, who will undertake agbiotech R&D; 2) modestly equipped facility and infrastructure; 3) adequate budgetary support from government and other investors; 4) the presence of institutional policy and incentive frameworks; and 5) a strong R&D organization and structure, and style of R&D governance.

The consequences and ramifications of the treaties and agreements on IPR, agbiotech, and PGR especially for Asian member [developing] countries are encompassing. The following discussion focuses on some of the implications of these international agreements to public sector R&D institutions:

Impact of Strengthened IPR on Local Biotechnology R&D

The bulk of agricultural R&D investment and activities in Asian developing countries are still almost entirely in the public sector universities and research institutions (Heisey 2001; Piñeiro 2007). The increasing IP ownership on modern biotechnology tools, products, and processes worldwide, however, poses significant challenges as to their acquisition, transfer, and commercialization

by public sector institutions in developing countries, which are dependent on technologies generated by developed nations. This has been experienced in the United States, where the proportion of privately held genetic material has rapidly increased in recent years (Delmer et al. 2003). These scenarios are expected to happen also in developing countries.

Access. IPR presents complex issues and challenges for public research institutes regarding the use of IPR owned by others. Access to biotech components and processes could require formal and informal agreements with international public research centers, development institutions and universities, and multinationals to avoid infringement of IPRs. As Maredia et al. (2004) emphasized, the inventor of a new transgenic variety may have to hurdle addressing the following types of prior IPR: 1) protected varieties into which the genetic material is to be inserted; 2) patented gene insertion techniques; 3) patented gene promoters; 4) patented marker sequences; and 5) previously incorporated patented traits (and their underlying genetic sequences). The high degree of fragmentation of technology ownership across numerous institutions adds to the problem. When IP rights for agricultural materials and technologies are held by multiple public and private sector owners, this fragmentation produces situations where no single institution can provide a commercial partner with a complete set of IP rights to ensure freedom to operate (FTO)—the ability to practice or use an innovation—with a particular technology (Atkinson et al. 2003). The case of “enhanced beta-carotene” rice, which was reported to be based on technologies protected by up to 70 patents originally held by 31 different organizations, sets the best example (Kryder et al. 2000) of this type of complexity. Other types of biotech inventions may have similar problems with previously held patents. It is still an open issue as to how much information in genomics and proteomics will be available in the public domain, and how many will be patented and available for a fee (Maredia et al. 2004).

Thus, proprietary interests in biotechnology will affect public R&D institutions in several ways, requiring them to consider issues that relate to the licensing of technology owned by developed countries or multinational companies, FTO aspects, and commercialization issues. Acquiring biotech IPs through licensing may, however, not be the

best option for public sector institutions because of budget constraints. Similarly, Graff et al. (2003) note that negotiations, paperwork, and licensing fees make for high transaction costs in obtaining R&D inputs. Because of strategic access considerations, IP right owners may refuse to license enabling technology tools, even for developments outside their own product scope.

Pardey et al. (2003), however, say that the concern about current developing-country access to essential IP is exaggerated and largely misdirected, and that the relationship between IPRs and agricultural research and NARES in developing countries is poorly misunderstood. Agricultural research centers have far greater FTO in agricultural research on food crops for the developing world than is commonly perceived. They claim that agricultural researchers are freer than one might think to make use of innovations protected in the developed countries because there is no such thing as “international patent right”.

Another way to access technologies is through humanitarian licensing, which was pioneered by the Golden Rice Humanitarian Board. The Golden Rice™ is one of the best illustrations of humanitarian IP management (Brewster et al. 2005)—the rice can be used royalty-free and farmers can earn as much as \$10,000 per year from its sales. Others, like the Public Intellectual Property Resource for Agriculture (PIPRA), the Public Interest Intellectual Property Advisors, Inc., and the International Services for the Acquisition of Agri-Biotech Applications likewise support agricultural innovation for both humanitarian and small-scale commercial purposes. Some recent humanitarian donations in agbiotech include the genetically engineered tomato and eggplant.

Presently evolving in the agbiotech industry is a new style of IP access called “open source” licensing. “Open Source Biotechnology” refers to the possibility of extending the principles of commerce-friendly, commons-based peer production exemplified by Open Source software development to the development of research tools in biomedical and agricultural biotechnology (Hope 2007). The Biological Innovation for Open Society (BiOS) Framework by CAMBIA, for instance, works on this initiative towards developing new licensing and distributive collaboration mechanisms to promote open access for biotechniques like

Transbacter, an alternative to *Agrobacterium tumefaciens* transformation to splice non-native genes to plants (Pollack 2005).

Tech-transfer and commercialization. Under patent laws, all unauthorized commercial use of patented matter within the territory of coverage is prohibited. If authorized, the royalties are expected to defray for research program costs. The seeds of plants covered by a patent/PVP could eventually be more expensive than other seeds available in developing countries [which allow seed patenting and PVP], but then, the latter will not contain the advantages of the protected invention. If R&D institutions want to commercialize locally developed agbiotech crops in which IPR-protected technologies are incorporated, they are legally obliged to negotiate and renegotiate with the IPR holders the terms and conditions under which commercialization take place. If no agreement on waiving of IPR rights is reached, delay in commercialization could occur.

Embracing IPR or not: Impact on Public Sector's Mission

Public sector institutions in developed countries, especially US universities have increased their patenting in modern agbiotech (Heisey et al. 2005). NARES in developing countries, which allow protection for life forms, may also want to protect biotechnology innovations, which they have developed themselves. This raises several issues, opportunities, and challenges. One concern is that agri-biotech products generated by NARES should not be protected because they are supported by public funds and thus should be 'public goods' and freely available. However, it is economically and socially justified for a public research institute to protect its IP when this helps to negotiate public-private cooperative relationships that hasten the development and commercialization of new products and services, particularly when the public sector does not have the business skills and venture capital to bring the products to market (Maredia et al. 1999). Take the case for instance of *Blumea balsamifera* ('sambong'), which was developed by the National Integrated Research Program on Medicinal Plants (NIRPROMP), an agency under the Philippine Council for Health Research and Development (PCHRD). Aside from

its useful features, the protection of this medicinal plant product facilitated its commercialization; the product is currently being marketed by a Philippine private company, Pascual Laboratories, Inc.

Meeting IP management costs. Building capacity in IP management at the institution level, however, involves both fixed and variable costs. The fixed costs include the establishment of an IP management office, building in-house human resource capacity in IP management, providing training to researchers and managers, and creating awareness among researchers. Research institutes and programs also incur variable costs in the form of patent filing fees, fees for database searches, legal fees for preparation of applications for plant variety, patent and other forms of protection, negotiation costs, and costs related to accessing a specific piece of proprietary technology.

Expanded IPRs and Implications to Public Sector's Plant Breeding Programs

According to Evenson (1999), there are two major specific implications of expanded IPRs for public sector plant breeding programs. The first is that they provide incentives for an expansion in private sector plant breeding activities, which provides competition for public programs, thereby inducing a positive response from the latter. The second is that there will now be two sources of supply of genetic resources to public programs—the traditional public sector gene bank nursery system, and the genetic resources that are for sale or licensing from private firms holding IPRs on them.

The Genetic Resources Action International (GRAIN 1998), the Commission on Intellectual Property Rights (CIPR 2002), and other NGOs argue that the "essential derivation" provision of PBR gives stricter enforcement, wider scope of monopoly rights, and thus restricts free use and access of protected varieties by public breeding institutions of UPOV member-countries or with PVP-UPOV based laws.

Breeders' exemption still plays a key role in the UPOV–PVP system. The new provision on essential derivation prevents the monopolization of a particular breeding aim and was introduced specifically to block genetic engineering companies from getting new PVP protection on varieties just

because they added a single gene (UPOV 2003). The breeders' exemption reflects the view of UPOV that the worldwide community of breeders needs access to all forms of breeding material to increase genetic diversity, sustain greatest progress in plant breeding and, thereby, maximize the use of genetic resources for the benefit of society. This issue is closely linked with measures to control access to PGR as envisaged in CBD, and with concerns that biodiversity be maintained since it is the source of future breeding genetic resources.

Public sector breeders, despite the strengthening of IPRs for varieties, have the free use of commercial varieties for research purposes. The issue of "essential derivation" will only be significant if these institutions wish to protect and/or commercialize varieties that are "essentially derived" from an existing one. The exploitation by breeding institutes of plant varieties that are protected under PBR/PVP require authorization and/or payment of royalties in the rare event that the newly bred commercialized variety is considered to be essentially derived from the initial variety. Thus, today, virtually all plant breeding initiatives, whether public or private, should best begin with an IPR search (Evenson 2004) to be aware and avoid infringing the rights of previous breeders.

Stringent Biosafety Requirements for GMO Research

According to Bhagavan and Virgin (2004), biosafety compliance is somewhat complex and demands lots of resources and thus could serve as a major obstacle for biotech R&D. Likewise, Greef (2004) notes that current developments in the regulation of biotech, particularly in the Cartagena Protocol, represent a serious threat to the efforts of public research to create sustainable solutions for the food security and health problems of the developing world. A looming issue specifically revolves around the compliance costs for regulatory approval that could be prohibitive for many developing-country institutions.

Access and Benefit-Sharing of PGR

The public sector research culture has a long tradition of open sharing of genetic resources,

germplasm, and research findings between research centers. Extensive collections of landraces, mutants, wild species, weedy relatives, and advanced breeding lines exist for most important crops. This tradition of open sharing and exchange of genetic materials is now under threat. Efforts to collect germplasm would now require institutions or individuals to comply with several national guidelines such as securing of permits and free and prior-informed consents, especially when collection is done in ancestral domains. Mutually agreed terms of benefit-sharing and other contractual arrangements among parties involved shall also need to be imposed and carefully executed.

Gene bank managers will increasingly cater to the needs of biotechnologists and molecular biologists in addition to breeders and other researchers. They would need to accelerate efforts in characterizing germplasm collections, and screening using molecular markers for favorable alleles and quantitative trait loci (QTL) for biotic and abiotic stresses. Reliable databases, constantly updated through new information technology, need to be developed. Aside from helping conserve germplasm collection and conservation, a fast emerging role for gene bank managers and PGR workers, in partnership with tech transfer personnel, relates to IPR issues and the development of workable material transfer agreements (MTAs) vis-à-vis the implementation of the provisions of various PGR-related agreements and international treaties. The provisions of the Standard MTAs of the ITPGRFA shall serve as guide for these contracts to facilitate access and standardize benefit-sharing requirements for crops covered by the multilateral system established by this treaty. The gene bank manager/curator will also play an important role in safeguarding the rights of farmers to their resources, knowledge, technology choices, and production systems as protected under national laws.

THE RESPONSE OF NARES IN THE PHILIPPINES: THE CASE OF PHILRICE

PhilRice, a government instrumentality attached to the Department of Agriculture in the Philippines, was created in November 1985 to

help develop high-yielding and cost-reducing technologies. It accomplishes this mission through research, development, and extension (RD&E) through its central and branch stations coordinating with a network that includes 57 agencies and 95 seed centers strategically located nationwide. An ISO 9001, ISO 14001, and OHSAS 18001-certified agency, PhilRice has about 700 regular and contractual personnel.

Rice Biotechnology R&D Initiatives

As a key component of varietal improvement, PhilRice in 1989 embarked on a modest but organized effort to access and use agbiotech. It sent an initial batch of scholars to the United States for Ph.D. training in biotechnology under the sponsorship of the Rockefeller Foundation (RF). In 1991, PhilRice generated support from the Japanese government through the Japan International Cooperation Agency (JICA) for its laboratory facilities and infrastructure.

The biotechnology activities of the institute is aimed at complementing the development of varieties for different ecosystems and problem areas by providing a tool that will allow faster transfer of traits, incorporation of genes from other species, and molecular characterization of varieties. Biotechnology is combined with other tools and approaches to optimize its effectiveness.

Establishment of biotech facilities and conformance with national biosafety requirements. Biotech-related research at the institute is undertaken in the genetics and tissue culture laboratories equipped with facilities for transgenic work, anther culture, and molecular marker analyses, including a CL2 greenhouse for contained greenhouse testing of transgenic rices. These and other facilities for transgenic work conform to the requirements prescribed by the National Committee on Biosafety of the Philippines (NCBP). Also, PhilRice has been authorized to conduct contained field-testing for bacterial blight “BB” rice, a project in collaboration with the International Rice Research Institute.

Manpower training. The manpower build-up is geared toward the development of a core staff competent in biotechnology research. Most of the personnel involved in agbiotech had formal

and informal training, which were sponsored by international organizations like JICA, the Asian Rice Biotechnology Network (ARBN), and many others.

Linkages with biotechnology institutions.

The biotechnology activities benefit much from advances in other laboratories, both local and abroad. PhilRice has pursued collaboration with the Asian Rice Biotechnology Network (ARBN), Rice Genome Program of Japan (JRGP), National Institute of Agro-biological Resources, Japan, and Center for the Application of Molecular Biology to International Agriculture (CAMBIA), Australia. There are ongoing collaboration with IRRI, Rutgers University, and the University of Freiburg (lead institution in the “Golden Rice Network”). Moreover, senior researchers also maintain good linkages with their former professors and colleagues from advanced laboratories around the world. These help PhilRice scientists gain new knowledge and expertise on specific technologies and their applications, as well as biosafety, technology transfer, and policy and planning issues relevant to NARES.

IPR Management Activities

IPR management capability-building at PhilRice started only in 2003. Efforts concentrated on the issuance of appropriate orders and policies, setting up of an IP management office, development of necessary institutional legal instruments and agreements, and human resource development.

PhilRice’s IP policy and implementing guidelines. PhilRice’s IP Policy leads its staff into a better understanding of the dynamics of technology transfer, and into making more effective use of available technologies like agbiotech. Further, the policy is promulgated to provide rules and guidelines that can help strengthen the capabilities of PhilRice researchers and scientists to deal with technology generation, acquisition, and transfer. The implementing guidelines of PhilRice’s IP policy cover: 1) who and what are covered by the policy; 2) who will use and administer the policy; 3) how innovations will be handled; 4) what are covered by the IP; and 5) the management of royalties and benefits.

PhilRice's IP Management Office (IPMO). Established to help PhilRice manage its IP, the IPMO has the following powers and functions: 1) to implement the IP Policy in harmony with other PhilRice policies, and ensure compliance by all PhilRice inventors, authors, breeders, and third parties; 2) to promulgate rules and regulations, and devise forms to effectively and efficiently implement the policy guidelines; 3) to manage PhilRice IP and proprietary information for the benefit of the Institute, the inventors, and the public; and 4) to handle all technology transfer arrangements and the commercialization of IP and proprietary information.

IP instruments and agreements. To ensure compliance with PhilRice's IP policy, several legal instruments have been developed and standardized, namely, IP undertaking, deed of assignment, confidential disclosure agreement, material transfer agreement, and licensing agreements.

Capability training efforts. This component focuses not only on the dissemination of the new IP policy and its guidelines but also in spreading the importance of IPR in the institutional and national levels, preparing and filing patent applications, negotiating and licensing a protected technology, patent documentation and search, and even the drafting of claims.

IPR management strategy. Since significant resources are needed to acquire IPRs for all PhilRice inventions, only those with great commercial appeal and usefulness to the industry are being pursued for patenting and other forms of IPR protection. The decisions and tasks related to this matter are handled by the IPMO.

PhilRice's PGR Management Efforts

PhilRice plays a major role in the protection, conservation, and promotion of sustainable use of the country's PGR. Its 6,000 ex situ collection is composed of modern and traditional rice varieties, breeding lines, special purpose rices, foreign introductions, hybrid parental lines, and wild rice accessions. The Institute adheres to the principle of unrestricted access to its rice germplasm collection for research and breeding purposes. The sharing of PhilRice germplasm collections is formalized through MTA executions stipulating conditions under which the recipient can use the germplasm. A

licensing agreement, on the other hand, is executed if the recipient decides to use the PhilRice-owned germplasm (i.e., those with PVP certificates) for commercial purposes.

STRENGTHENING NARES IN ASIA

NARES institutions in Asia are challenged to improve their performance amid current international developments which have great influence on their funding levels, research focus, and R&D output dissemination strategies. NARES have to redefine their roles and upgrade their expertise in this changing world of new science, with new norms about the ownership, sharing, and use of research products. The following courses of action are suggested for Asian NARES:

Capacity-Building

Evenson et al. (2002) point to capacity-building among public sector NARES programs as one of the issues that needs to be addressed if public agricultural researchers are to avoid the delays associated with international regime developments. Specifically, training in the science and management of biotechnology, IPR, biosafety, and international negotiations is generally perceived as an overwhelming need for public sector institutions in developing countries (Herdt 1999).

Agbiotech Management

The new paradigm offered by the so-called Second Green Revolution requires developing countries to acquire new skills to access, use, and manage proprietary biotechnologies (Maredia et al. 1999). The following are suggested to facilitate the generation and diffusion of agbiotech products:

Institutional biotech R&D prioritization. Agbiotech should be targeted to solving specific problems where it offers a comparative advantage, for instance, where conventional breeding has not been successful. These include research activities where conventional breeding takes a long period to generate advance lines, where screening procedures are very tedious or difficult, and where desired characters are not available in the rice gene pool such as tolerance to adverse conditions, grain quality, and pest and disease resistance, among others.

Priority-setting should take into account national development policies, private sector interests, and market possibilities. A diversity of stakeholders should likewise be involved in the formulation of institutional biotechnology strategies, policies, and plans, ending up in a market-driven approach.

Access and use of other biotech IPs. There is a need to balance the fact that, on one hand, public sector institutions, due to limited resources, cannot fully avoid accessing private sector-held IP during the development of its own products and, on the other hand, the private sector has to avail of IPR protection to be able to protect its investments and commercial interests as well to be able to share their IP with other sectors without fear of exploitation. Examples of these proprietary technologies, called “enabling technologies”, include the Agrobacterium vector, the CaMV/35S promoter, the Cry genes for insect resistance, selectable markers like GUS, and the kanamycin and hygromycin resistance genes. Direct purchase of genes and technologies, licensing, [the fact that patents have time limits], confidential agreements, and the purchase of genes for incorporation into local germplasm are some modalities the public sector can explore to access these genes and technologies from the private sector (Redona and Mula 2004). There are also alternative strategies to gain FTO and these include 1) inventing around current patents; 2) redesigning constructs to synthesize genes to reduce reliance on external technical property; 3) asking IP owners to relinquish claims or provide royalty-free licenses; 4) ignoring all IP and technical property; or 5) seeking licenses for all IP and commercial property (ADB 2001).

Pursuing public-private sector partnership. NARES have to develop innovative mechanisms to work with the private sector to access needed tools and technologies, recognizing the complementary goals, skills, and assets. Germplasm and associated biological knowledge are NARES’ critical assets that they can use as bargaining chips to obtain access to agbiotech tools and products, especially when they serve emerging commercial markets of interest to the private sector (Byerlee and Fischer 2001). Several advanced NARS have explored this initiative and have had successful partnerships with large firms to develop new technology. The Agricultural Genetic Engineering Research Institute (AGERI), and Egyptian public research

institute, and Pioneer Hi-Bred, for instance, have developed a new Bt gene. As reflected in the 2004 FAO report, this partnership enables AGERI to gain access to expertise to develop the local strain of Bt (the innovation) and to educate its staff while Pioneer Hi-Bred pays the legal costs of patenting the invention and has access to the new Bt strain for use in markets outside Egypt. However, for other Asian NARS to reap the same success, they must develop IP management capacity and business skills, and clearly identify the value of their own assets in the negotiations.

Participation in the improvement of national biosafety rules. Implementing biosafety policy should not end once guidelines are written, people are trained, and reviews are conducted. It is a dynamic process that evolves through mechanisms for incorporating new information (Traynor 1999). Though it takes time to create new laws and guidelines, and modify them to adapt to new developments, NARES institutions must still participate and contribute in assessing how well the system is working and providing procedural feedback on biosafety guidelines and implementation procedures.

Institutionalizing IPR Management Strategies

To comply with national IPR policies and keep up with the rapidly changing “rules of the game”, NARES have to take up many organizational and management challenges that require more human and financial resources and knowledge, skills, and expertise in non-agricultural fields of study. These include: the creation of an IP management and technology transfer office; the development of negotiation skills and bargaining power; understanding and honoring IPR legislation and agreements; and meeting the financial burden of maintaining an IPR management system. Technology transfer personnel, researchers, and decision-makers likewise need special IPR management training on such areas as negotiation exercises, illustrations and case studies of public-private partnerships, end-user considerations, and other management responsibilities.

Institutional IPR Policy. This can guide the institution, including its researchers and scientists, in making decisions and maximizing the benefits derivable from agbiotech research vis-à-vis IP

architectures. With IP policy and institutional mechanisms in place, any form of biotechnology should be within the reach of any agency and the society it serves.

In making decisions about the use and protection of an IP technology, NARES have to weigh the benefits against the social costs to farmers and consumers, and the public expectation that all IP created by a public research program should be made available free of charge and without restrictions. They need to assess the most effective way of generating public benefits from an innovation since IPR protection and restricting its use for the primary purpose of generating income through royalties is not compatible with the responsibilities of a public institution. Although NARES should respond to the new IPR scenario, they are still in the business of public research and producing non-proprietary technologies that are transferred to farmers and other clients without cost. However, in special instances, protecting an innovation and assigning its production exclusively or non-exclusively, may be the most desirable action to ensure the promotion and utilization of an innovation.

NARES need to distinguish between using IPRs in order to control the use and delivery of their varieties, on one hand, and seeing IPRs as a contributor to an institution's budget through royalties (Eaton et al. 2005). Furthermore, NARES have several options that give them control over the outcomes of their R&D programs. Even with the increasing trend toward protection, a public institute has the option not to protect the technology, unless required by a funding agency. If the decision is made to protect a technology, in practice, a public institution still has control over the terms and conditions negotiated in an MTA or a license agreement to mitigate the negative impacts of IP protection on the public sector mission. Another option is defensive publication as suggested by Adams and Apollonio (2002). If the defensive publication is made widely available, the invention could no longer be considered as novel and will thus be considered a public good internationally; hence, no other institution can claim ownership of it.

Establishment of an IP Management Office. NARES may consider establishing an IP management and technology transfer office that shall 1) develop institutional IPR policies; 2) regulate the division of revenues generated from

institutional IP; 3) educate and create awareness about IPR among researchers and management personnel; 4) handle day-to-day IP management for the institution, including patent filing, applying for PVP protection, database searches, contracts, and agreements interpretation, negotiations, and prosecution; 5) act as a research liaison office to help researchers access and negotiate proprietary technologies from the owners; 6) monitor latest developments in agbiotech R&D arena and information on alternative technology sources to improve the organization's bargaining position in negotiating for technology transfer agreements with the private sector; and 7) assess the accountability requirements and public expectations regarding innovations produced with public funds.

The day-to-day management of institutional IPR is quite an intensive investment basing from PhilRice's experience. Developing an in-house management capacity will, however, be a great help for scientists so they won't have to deal with IPR matters themselves. The challenge is to determine the efficient size and scope of an IP management office.

Access and Benefit-Sharing of PGR

NARES maintaining gene banks or with genetic resources collections need to have in place a legal instrument to facilitate exchange. Member-countries of CBD can implement CBD standard-friendly MTAs by CBD or ITPGRFA which generally set out permitted uses of material, terms for supply to others, requirements for benefit-sharing, and usually, non-commercialization. Additionally, NARES should ensure that free and prior informed consent of concerned farmers and local communities is obtained before bioprospecting is done; adapt current variety registration systems to identify and record, as appropriate, varieties of PGR especially those provided by farmers and farming communities, and their sources; and require disclosure of the origin of PGR utilized in the development of commercial varieties.

CONCLUSION

NARES need to continually build and strengthen their internal and external capabilities as instruments to enhance their technical efficiency, R&D

productivity, and organizational competitiveness. This will contribute to their respective national innovation system, and help address their country's food security and poverty alleviation objectives in line with achieving the UN Millennium Development Goals.

International treaties and conventions present significant opportunities toward providing international regulatory frameworks for the rapidly evolving agriculture sector. They create an enabling environment for the sound management of agbiotechnology. On the other hand, they pose a challenge for signatory countries to formulate policy and legislation, handle the interlinking issues on agbiotech, IPR, and PGR in line with international obligations, and enforce and regulate them in a pro-competitive manner that is appropriate to the levels of national development. However, compliance with these agreements entails both benefits and costs.

The PhilRice's experience demonstrates that international and national regime developments governing agbiotech should not serve as a hindrance but should, in fact, facilitate access to agbiotech and its eventual commercialization for the benefit of the whole society. Whether or not other NARES institutions in Asia have already experienced the effects of the growing importance of IPR and increased pressures of biosafety compliance as they affect agbiotechnology R&D, it is safe to assume that most of them will have to do so in the near future in accordance with national and institutional policies. NARES, however, should not be driven away from their broader societal objectives. They need to balance their role in providing public goods such as GM crops to ensure sustainable funding, access proprietary tools and products, and efficiently disseminate their products to the society they serve.

As Wright and Pardey (2006) have reported, public agricultural research in developing countries has been less constrained by the international regime developments regulating the interplay of agbiotechnology, IPR, and PGR. Such experience offers important insights for the dozen or so developing countries with substantial near-term potential for agbiotech development and application. Governments then should, as much as possible, capitalize on potential opportunities offered by the obligations set by these international treaties and

conventions. Advocating for institutional policy and initiatives is critical, aside from enacting legislation, administration, and enforcement. In the end, the effects of these treaties will depend on the capacity of countries to seize the advantages, on ways countries choose to implement them, and on the conditions existing in a given country.

REFERENCES

- Asian Development Bank. 2001. "Agricultural Biotechnology, Poverty Reduction, and Food Security". http://www.adb.org/Documents/Books/Agri_Biotech/default.asp
- Association of Southeast Asian Nations. "ASEAN Intellectual Property Right Action Plan 2004-2010". <http://www.aseansec.org/17071.htm>
- Adam, S. and V. Henson-Apollonio. 2002. "Defensive Publishing: A Strategy For Maintaining Intellectual Property As Public Goods". Briefing Paper 53. International Service for National Agricultural Research.
- Atkinson, R.C., R.N. Beachy, G. Conway, F.A. Cordova, M. Fox, K.A. Holbrook, D.F. Klessig, R.L. McCormick, P.M. McPherson, H.R. Rawlings III, R. Rapson, L.N. Vanderhoef, J.D. Wiley, and C.E. Young. 2003. "Public Sector Collaboration for Agricultural IP Management". *Science*, 301 (July): 174-175
- Ballentine's Law Dictionary. 1969. 3rd edition.
- Bhagavan, M.R. and I. Virgin. 2004. "Agricultural Biotechnology in Developing Countries: A Briefing Paper for SIDA". Stockholm Environment Institute.
- Beronio, R.A., J.G. Payumo, and C.A. Arceo. 2006. "Biotechnology and Intellectual Property Rights: An Evolving Helix of Science and Law". In B. Peczon and A. Manalo, eds., *Straight Talk in Biotechnology*.
- Beronio, R.A. and J.G. Payumo. 2006. "Implications of TRIPS on Asian Agricultural Trade and Development, and Agenda for Effective Compliance among Asian Members". Seminar Paper 06-04. Asian Productivity Organization and the Pakistan Agricultural Research Council, Faisalabad, Pakistan.
- Biodiversity International (no date). "Asia, the Pacific and Oceania". http://www.biodiversityinternational.org/Regions/Asia_the_Pacific_and_Oceania/index.asp#
- Bragdon, S. 2000. "An Overview of International Instruments of Relevance to Plant Genetic Resources". Workshop Paper. International Plant Genetic Resources Institute, Rome, Italy.

- Borlaug, N.E. 2000. "Ending World Hunger. The Promise of Biotechnology and the Threat of Antiscience Zealotry". Editor's Choice. *Plant Physiology*, 124(October): 487-490.
- Brewster, A.L., A.R. Chapman, and S.A. Hansen. 2005. "Facilitating Humanitarian Access to Pharmaceutical and Agricultural Innovation". *Innovation Strategy Today*, 1(3): 203-216.
- Byerlee, D. and K. Fischer. 2001. "Accessing Modern Science: Policy and Institutional Options for Agricultural Biotechnology in Developing Countries". *IP Strategy Today*. <http://www.biodevelopments.org>
- Choudhary, B. 2002. "The New International Seed Treaty: Promises and Prospects for Food Security". *Current Science*, 83 (4).
- Commission on Intellectual Property Rights. 2002. "Integrating Intellectual Property Rights and Development Policy".
- Commission on Plant Genetic Resources. 1991. "Biological and Plant Genetic Resources and Elements of a Code of Conduct for Biotechnology". <ftp://ftp.fao.org/ag/cgrfa/cgrfa4/R4W12E.pdf>
- Consumers International Asia Pacific Office. 2003. "Fifth WTO Ministerial at Cancun: Deliver on Development". *Asia Pacific Consumer*, 33 (March): 1-42.
- Delmar, D.P., C Nottenburg, G.D. Graff, and A. B. Bennett. 2003. "Intellectual Property Resources for International Development in Agriculture". *Plant Physiology*, 133 (December): 1666-1670. www.plantphysiol.org
- Deng, S., P. Townsend, M. Robert, and N. Quesnel. 1996. "A Guide to Intellectual Property Rights in Southeast Asia and China". *Business Horizons*, 39(6): 43-51.
- Department of Environment and Natural Resources. 2004. "The National Biosafety Framework for the Philippines". <http://www.unep.org>
- Diaz, C.L. 2005. "Intellectual Property and Biological Resources". Wuppertal Institute for Climate, Environment and Energy.
- Eaton, D., N.P. Louwaars, R. Tripp, V. Henson-Apollonio, R. Hu, F. Muhhuku, S. Pal, and J. Wekundah. 2005. "Impacts of Strengthened Intellectual Property Rights Regimes on the Plant Breeding Industry in Developing Countries: A Synthesis of Five Case Studies". Conference Paper 05-07. International Consortium on Agricultural Biotechnology Research, Ravello, Italy.
- Evenson, R.E. 1999. "Intellectual Property Rights to Plant Germplasm, and Crop Production Scenarios in 2020". *Crop Science*, 39. 1631.
- _____. 2004. "Intellectual Property Rights and Asian Agriculture". *Asian Journal of Agriculture and Development*, 1(1): 17-38.
- Evenson, R.E., V. Santaniello, V. and D. Zilberman. 2002. "From the Green Revolution to Gene Revolution". *Economic and Social Issues in Biotechnology*. Wallingford, Oxon: CABI Publishing.
- Food and Agriculture Organization. 1996. "Role of Research in Global Food Security and Agricultural Development". Technical Background Document.
- _____. 1997. *Management of Agricultural Research: A Training Manual. Module 1: Institutional Agricultural Research: Organization and Management*. www.fao.org/docrep/W7500E/W7500E00.htm
- _____. 2000. "Multilateral Trade Negotiations on Agriculture - A Resource Manual/TRIPS Agreement". <http://www.fao.org/docrep/003/x7355e/x7355e02.htm>
- _____. 2001. "Electronic Forum on Biotechnology in Food and Agriculture: The Impact of IPR on Food and Agriculture in Developing Countries". www.fao.org/biotech/forum.asp
- _____. The State of Food and Agriculture 2003-2004- Agricultural Biotechnology: Meeting the Needs of the Poor? Series title: FAO Agriculture Series (SOFA) - 35. <http://www.fao.org/docrep/006/Y5160E/y5160e12.htm>
- _____. 2005. "Status of Research and Application of Crop Biotechnologies in Developing Countries. Preliminary Assessment". <http://www.fao.org/docrep/008/y5800e/y5800e00.htm>
- Food and Agriculture Organization of the United Nations. Science Council Secretariat. 2004. "Report of the Fifth External Programme and Management Review of the International Plant Genetic Resources Institute (IPGRI)". <http://www.fao.org/WAIRDOCS/TAC/Y5223E/y5223e00.htm>
- FAO BioDec data. 2006. <http://www.fao.org/biotech/>
- GRAIN, 1998. "TRIPS vs CBD: Conflicts between the WTO Regime of Intellectual Property Rights and Sustainable Biodiversity Management. Global Trade and Biodiversity in Conflict". <http://www.grain.org/briefings/?id=24>
- _____. "Signposts to Sui Generis Rights: Emerging National Responses". <http://www.grain.org/briefings/?id=174>

- _____. 1999. "Beyond UPOV: Examples of Developing Countries Preparing non-UPOV sui generis Plant Variety Protection Schemes for Compliance with TRIPs". <http://www.grain.org/briefings/?id=127>
- GRAIN and Kalpavriksh. 2002. "A Challenge for Asia - the International Treaty". <http://www.grain.org/briefings/?id=37>
- Graff, G.D., S.E. Cullen, K.J. Bradford, D. Zilberman, and A.B. Bennett. 2003. "The Public-Private Structure of Intellectual Property Ownership in Agricultural Biotechnology". *Nature Biotechnology*, 21 (9): 989.
- Greef, W. 2004. "The Cartagena Protocol and the Future of Agbiotech". *Nature Biotechnology*, 22: 811 - 812.
- Hautea, R.A. and M. Escaler. 2004. "Plant Biotechnology in Asia". *AgBioForum*, 7(1&2): 2-8.
- Helfer, L.R. 2004. "Regime Shifting: The TRIPS Agreements and New Dynamics of International Intellectual Property Lawmaking". *Yale Journal of International Law*, 29.
- Herdt, R.W. 1999. "Enclosing the Global Plant Genetic Commons". Conference Paper 99-05. China Center for Economic Research, Peking University, China.
- Hope, J. 2007. "What is Open Source Biotechnology?" <http://rsss.anu.edu.au/~janeth/>
- International Services for the Acquisition of Agri-Biotech Applications. 2005. "Global Status of Biotech/GM Crops in 2005". <http://www.isaaa.org/kc/bin/briefs34/es/index.htm>
- James, C. 2008. "Executive Summary Global Status of Commercialized Biotech/GM Crops: 2007". ISAAA Brief No. 37.
- Kryder, R.D., S.P. Kowalsky, and A. F. Krattiger. 2000. "The Intellectual and Technical Property Components of Pro-Vitamin A Rice (GoldenRice™): A Preliminary Freedom-to-Operate Review". ISAAA Brief No. 20.
- Marra, MC, P.G. Pardey, and J.M. Alston. 2002. "The Payoffs to Agricultural Biotechnology: An Assessment of the Evidence". Paper No. 87. International Food Policy Research Institute.
- Maredia, K.M., F.H. Erbisich, C.L. Ives, and A.J. Fischer. 1999. *AgbiotechNet*. Vol. 1.
- Maredia, M.K., J.F. Oehmke, and D. Byerlee. 2004. "Economic Aspects of Intellectual Property Rights in Agricultural Biotechnology". In F.H. Erbisich and K.M. Maredia, eds., *Intellectual Property Rights in Agricultural Biotechnology*. Second Edition.
- Musungu, S.F. and G. Dutfield. 2002. "Multilateral Agreements and a TRIPS-plus World: The World Intellectual Property Organization (WIPO)". Quaker United Nations Office and Quaker International Affairs Programme. 1-36
- Panutampon, P. and W. Lianchamroon. 1998. "Biopiracy, TRIPS and the Patenting of Asia's Rice Bowl". *Thai Development Newsletter*, 34 (January-June): 51-57.
- Pardey, P.G., B.D. Wright, C. Nottenburg, E. Binenbaum, and P. Zambrano. 2003. "Intellectual Property and Developing Countries: Freedom To Operate in Agricultural Biotechnology. In P.G. Pardey and B. Koo, eds., *Research at a Glance-Biotechnology and Genetic Resource Policies*". International Food Policy Research Institute.
- Pistorius, R. 1995. "Biodiversity Policies within FAO or CoP?". *Biotechnology and Development Monitor*, 25 (December). <http://www.biotech-monitor.nl/2508.htm>
- Piñeiro, M. 2007. "Agricultural Technology Transfer to Developing Countries and the Public Sector". *Sci Dev net*. Policy briefs (January). <http://www.scidev.net/en/policy-briefs/agricultural-technology-transfer-to-developing-cou.html>
- Pollack, A. "Open Source Practices for Biotechnology". *The New York Times*.
- Prakash, C.S. 2003. "Scientific Community Backs Agbiotech". *Rice World*, 3 (12): (December). <http://www.agbioworld.org/biotech-info/articles/interviews/riceworld.html>
- Redona, E.D. and F.L. Mula. 2004. "Some Imperatives and Challenges for Rice Biotechnology in Asian National Agricultural Research and Extension Systems". *Asian Biotechnology and Development Review*. http://www.ris.org.in/abdr_nov2005.htm
- Repetto, R.S. and M. Cavalcanti. 2002. "Basic Concepts of Intellectual Property Rights". www.fao.org/docrep/003/X7355E/X7355e01.htm
- Rothschild, G. (no date). "Advancing Biotechnology In Developing Countries: Introduction". <http://www.taa.org.uk/WestCountry/rothchild.html>
- Tanasugarn, L. 2002. "IP and Biotechnology in Southeast Asia". Conference Paper. BIOLAW 2002. Bangkok, Thailand

- Traynor, P.L. 1999. "Biosafety Management: Key to the Environmentally Responsible Use of Biotechnology". In J.I.Cohen, ed., *Managing Agricultural Biotechnology. Addressing Research Program Needs and Policy Implications*.
- UNCTAD and ICTSD. 2003. "Food, Agriculture and Biodiversity". UNCTAD-ICTSD Project on IPRs and Sustainable Development.
- UNESCO. 2006. "Asia Overtakes Europe in R&D Expenditure." <http://www.uis.unesco.org>
- van Wijk Jeroen, J. I. Cohen, and J. Komen. 2003. "Intellectual Property Rights for Agricultural Biotechnology: Options and Implications for Developing Countries". ISNAR Research Report.
- Wikipedia ®. 2008. "Asia". <http://en.wikipedia.org/wiki/Asia>
- World Intellectual Property Organization. 2006. "Traditional Knowledge, Genetic Resources and Traditional Cultural Expressions/Folklore". <http://www.wipo.int/tk/en/>
- Wright, B.D. and P.G. Pardey. 2006. "Changing Intellectual Property Regimes: Implications for Developing Country Agriculture". *Int. J. Technology and Globalisation*, Vol. 2 (1/2).
- World Trade Organization. (2008). "Index of Dispute Issues". www.wto.org/english/tratop_e/dispu_e/dispu_subjects_index_e.htm
- _____. "The WTO Agreement on the Application of Sanitary and Phytosanitary Measures (SPS Agreement)". http://www.wto.org/english/tratop_e/sps_e/spsagr_e.htm